

Chanceford Township

Stormwater Management Requirements and Procedures

- Stormwater Management is a necessary action to prevent stormwater and soil erosion damage to downstream properties and streams, and to recharge groundwater.
- Stormwater Management requirements are contained in the Chanceford Township Stormwater Management ordinance dated September, 1992.
- Stormwater management is required for the addition of any new impervious area (anything other than vegetative cover) larger than **400 square feet**.
- Typically, stormwater management is addressed during the subdivision plan process, so requirements will appear on the approved plans.
- *Design of stormwater management facilities by a Professional Engineer* is typically only required for very large or complex development. For normal use, the Residential Seepage Basin (Figure 7 attached) or the Residential Stormwater Basin (Detail attached) are adequate and easily constructed.
- Sizing of the Seepage Basin is easily done with the table attached.
- Questions regarding stormwater management in general and to secure a permit: Chanceford Township office, 51 Muddy Creek Forks Road, Brogue, PA. phone 717-927-6401 fax 717-927-8402 or email chancefordtwp@clearviewcatv.net
- Questions regarding stormwater management design: C.S. Davidson, Inc. Township Engineers, Attn: John Klinedinst, P.E., 38 North Duke Street, York, PA 17401 phone 717-846-4805, fax 717-846-5811 or email JAK@csdavidson.com
- Please be careful with location of stormwater management facilities with respect to your property lines, septic system, well, and house. Remember your downstream neighbors.

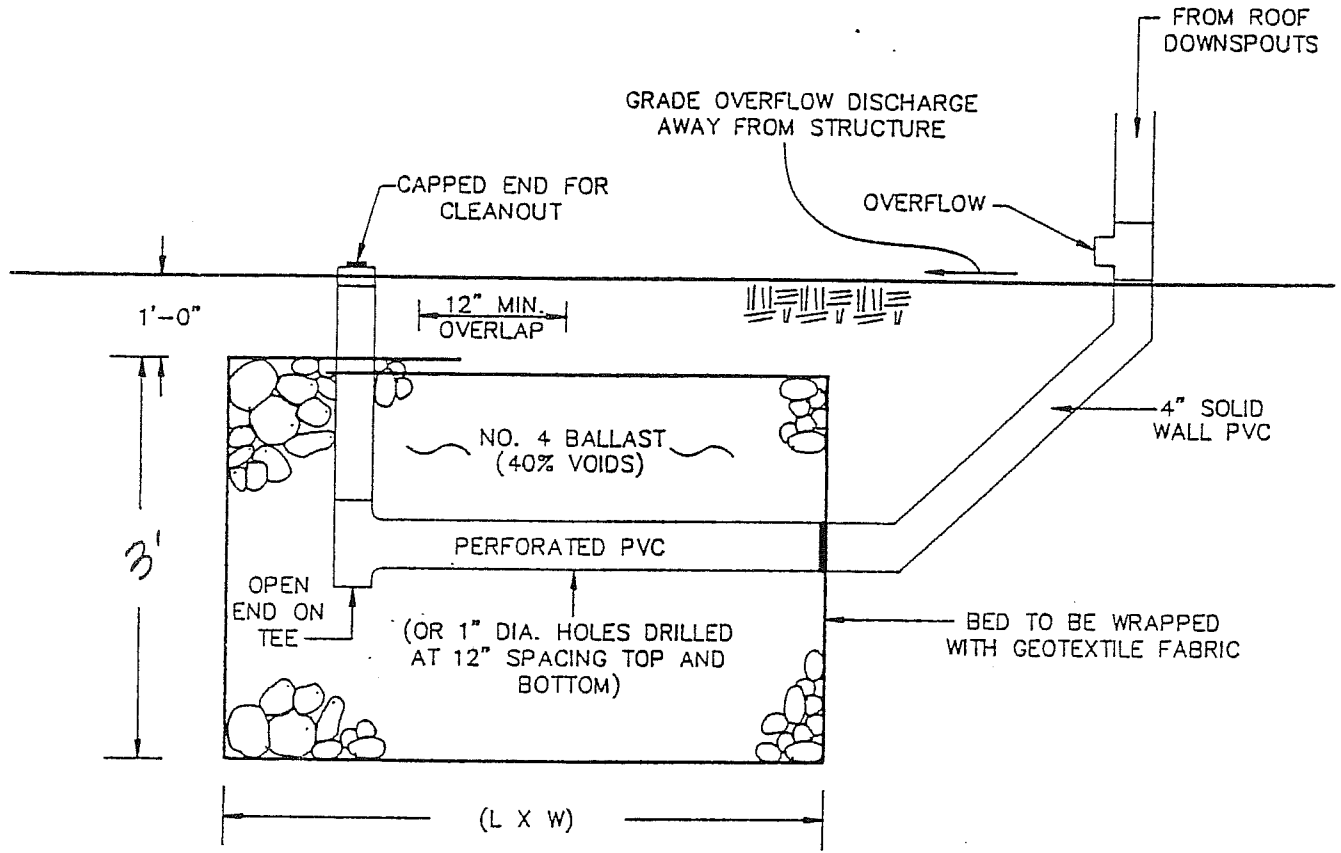

DESIGN PARAMETERS

- 10 YEAR STORM FREQUENCY
- CN=98, P=4.9" (RAINFALL), PR= 4.66" (RUNOFF)
- IMPERVIOUS AREA= _____
- PERC RATE = 2"/HR (ASSUMED)

FIGURE 7

C.S.DAVIDSON, INC.
 CONSULTING CIVIL ENGINEERS
 38 NORTH DUKE STREET YORK, PENNA.

TYPICAL
 RESIDENTIAL STORMWATER
 MANAGEMENT
 SEEPAGE BASIN

DATE: 8/20/92
 DRAWN BY: BAM
 CHK. BY:
 DWG. NO. 2201SEEP

GRADE ALL IMPERVIOUS
AREA (ROOF, DRIVEWAY)
TO DRAIN INTO
BASIN (TYP.)

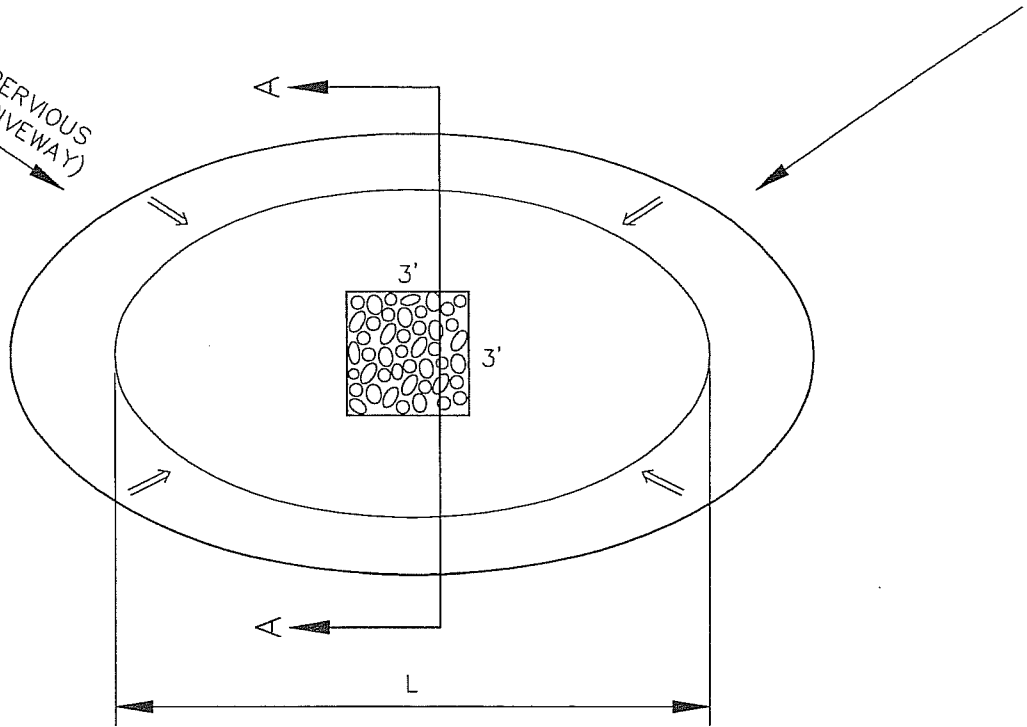

PLAN

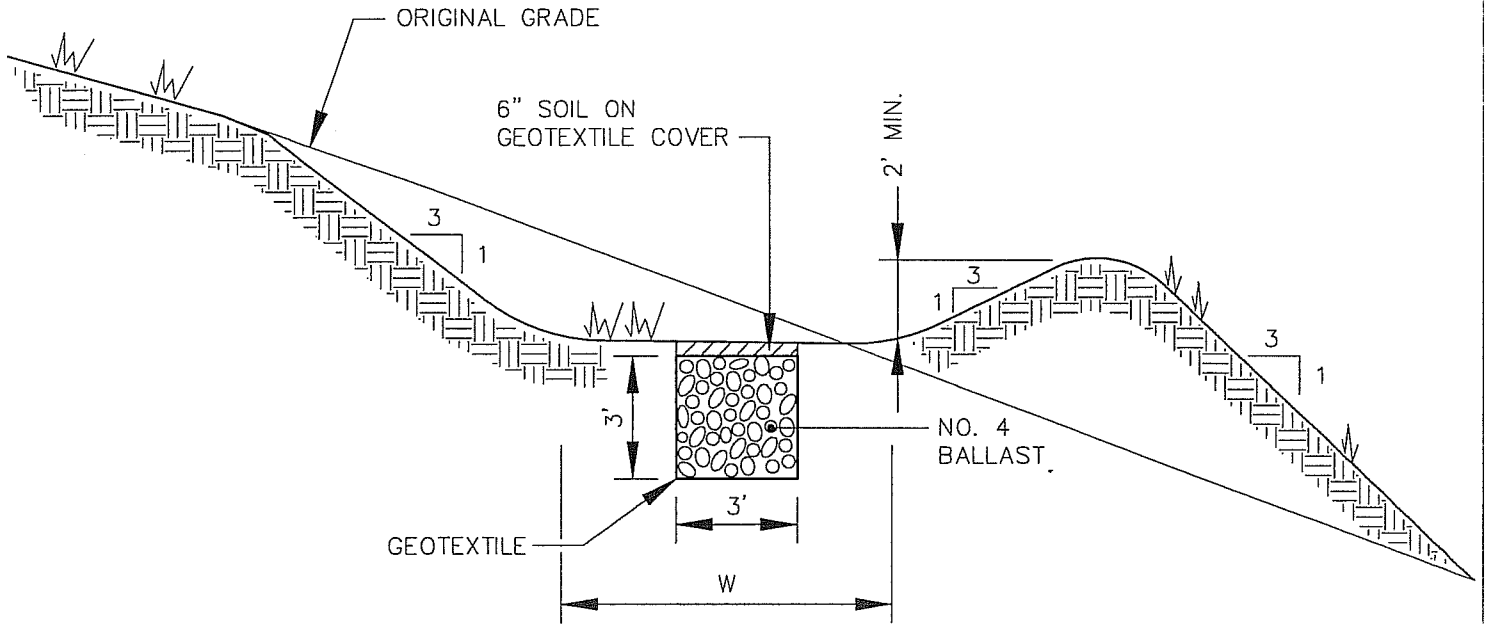

SECTION A-A

C.S. Davidson, Inc.

CONSULTING CIVIL ENGINEERS
38 NORTH DUKE STREET YORK, PENNSYLVANIA
PHONE NO. (717) 846-4805
FAX NO. (717) 846-5811
50 W. MIDDLE STREET GETTYSBURG, PENNSYLVANIA
PHONE NO. (717) 337-3021
FAX NO. (717) 337-0782

RESIDENTIAL
STORMWATER BASIN
DETAIL

DATE:	8/30/95
DRAWN BY:	BAM
CHK. BY:	
NO.	02270-2A

IMPERVIOUS
AREA (ROOF)
(SQ. FT.)

L x W *
(SQ. FT.)

400	55
500	70
600	80
700	95
800	110
900	120
1000	140
1100	150
1200	165
1300	175
1400	190
1500	205
1600	220
1700	230
1800	245
1900	260
2000	275
2100	290
2200	305
2300	320
2400	330
2500	340
2600	355
2700	370
2800	380
2900	395
3000	410
3100	425
3200	440
3300	450
3400	465
3500	480
3600	490

* SEEPAGE BED TO BE 3 FEET DEEP WITH 1 FOOT OF COVER